

STEP 1

NAIL FLOOR TRAP BODY TO FORM WORK

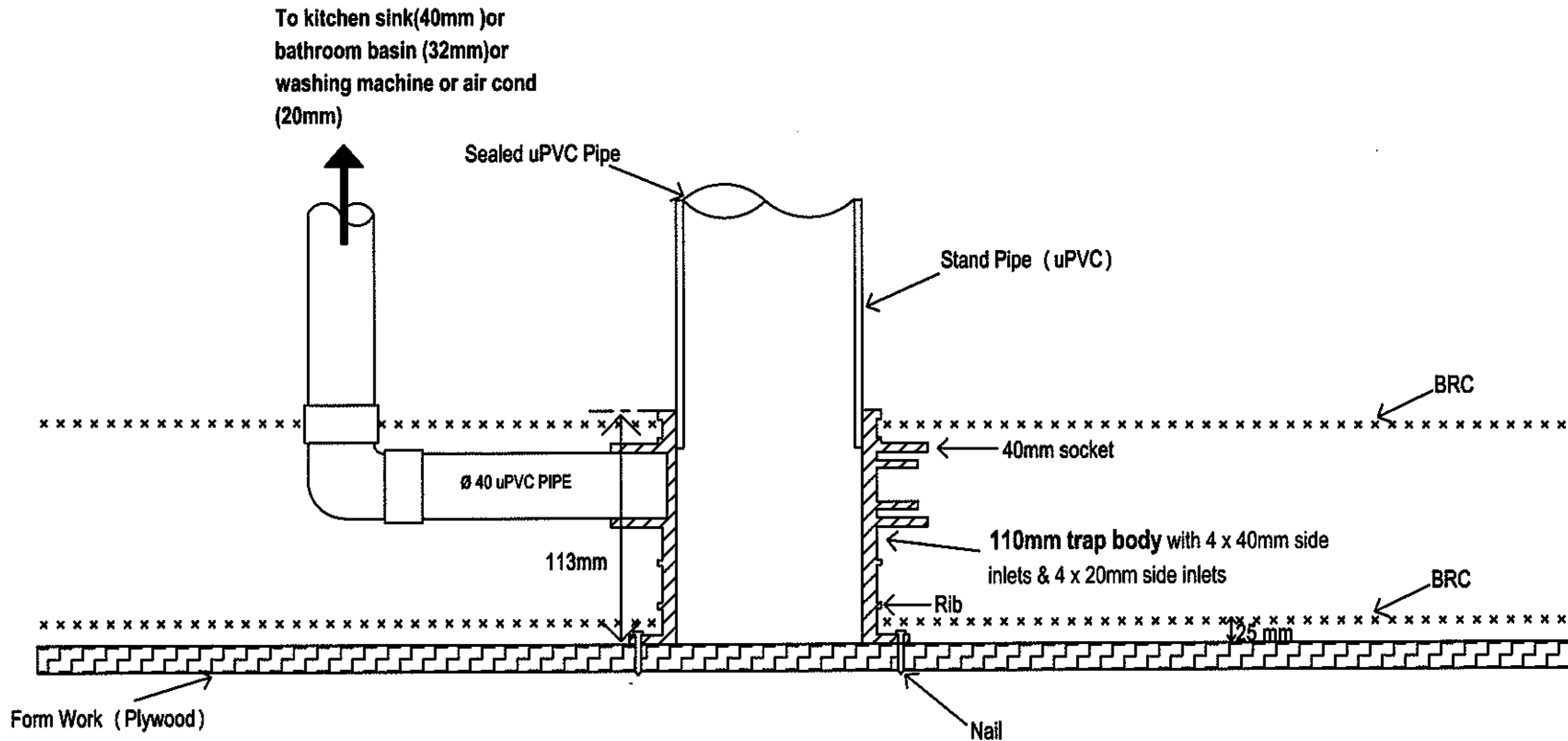

- a) **Nail / tie trap body to form work / BRC before pouring concrete.**
- b) **Make connections to air con pipe, basin, sink, etc (if any)**

STEP 2 FLOOR TRAP BODY IN SLAB AFTER CONCRETE

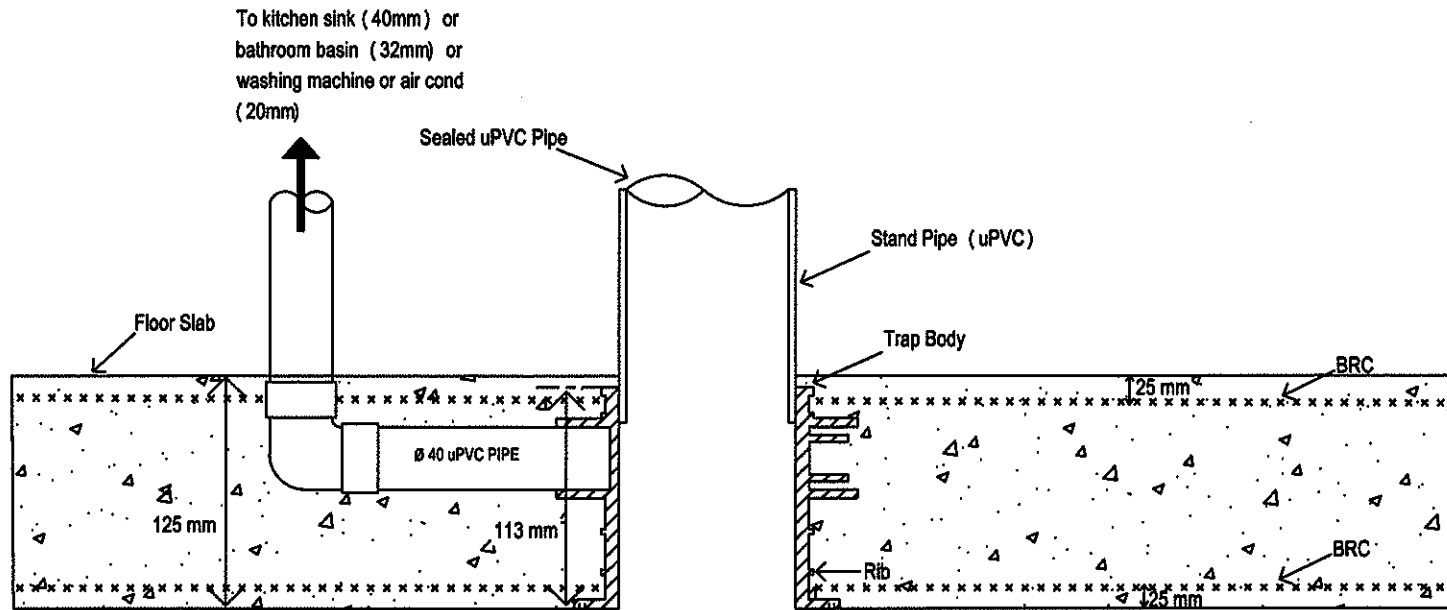

- a) Pour concrete for floor slab to required height.
- b) Wait for concrete to cure / harden.
- c) Remove form work

STEP 3

FLOOR TRAP BODY IN SLAB AFTER CONCRETE WITH OUTLET CONNECTION

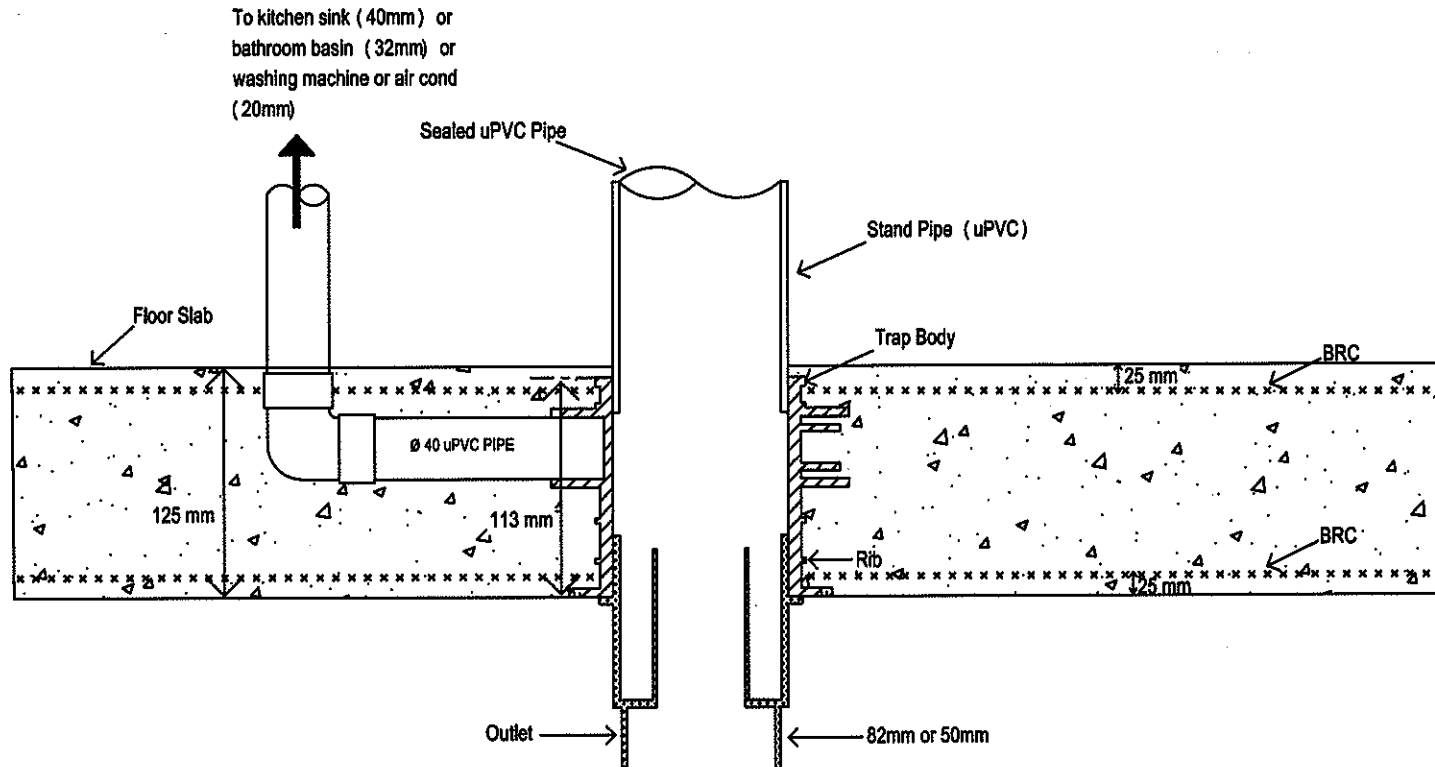

- a) Solvent cement outlet to trap body. Ensure that both bonding surfaces are clean before jointing

STEP 4

FLOOR TRAP BODY IN SLAB AFTER CONCRETE WITH OUTLET AND ELBOW WITH VENTING

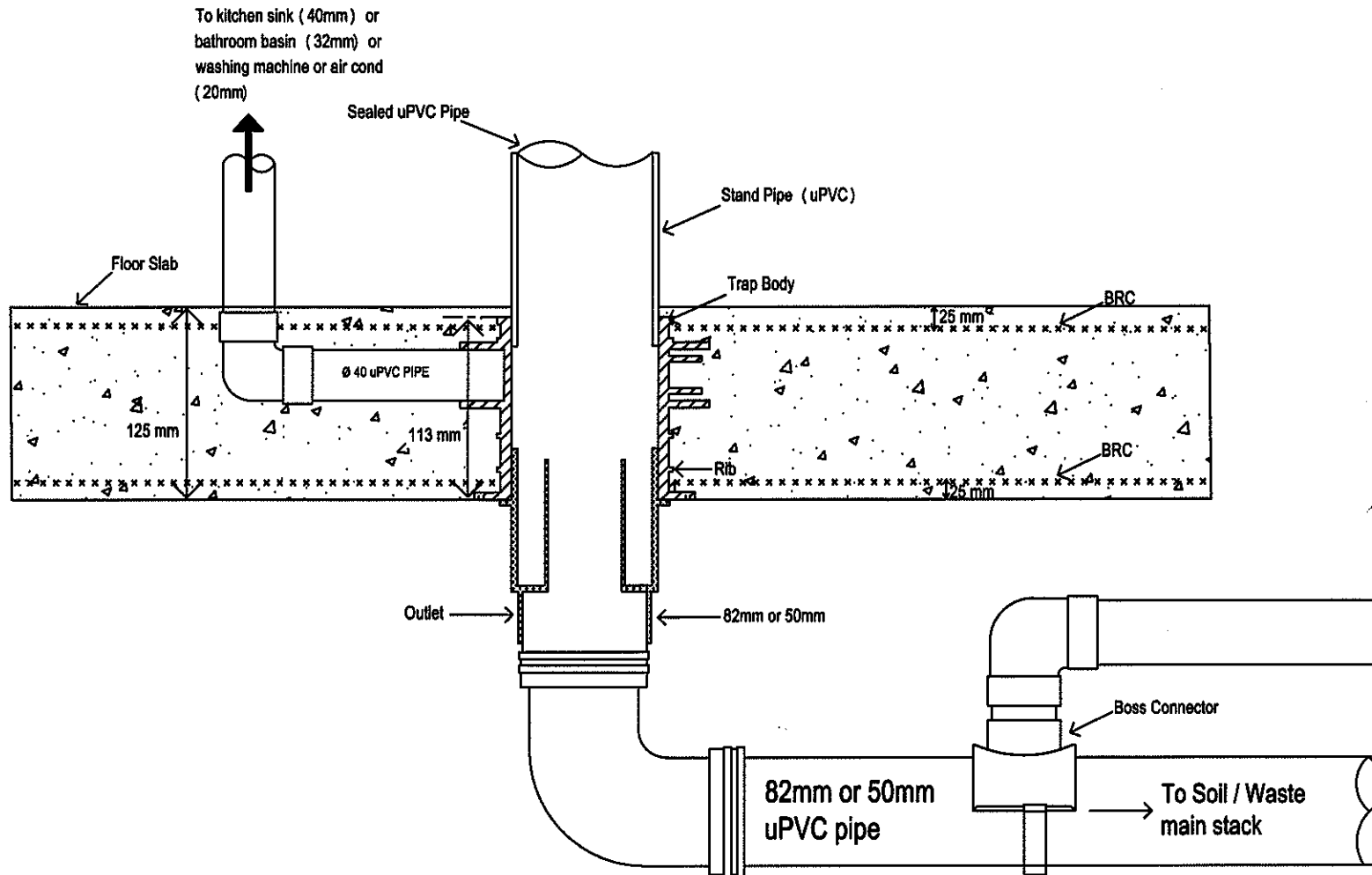

- a) Connect outlet of trap body to soil / waste main stack using suitable size elbow.

STEP 6

FLOOR TILE, COLLAR, BELL AND COMPLETE FLOOR TRAP INSTALLATION - END

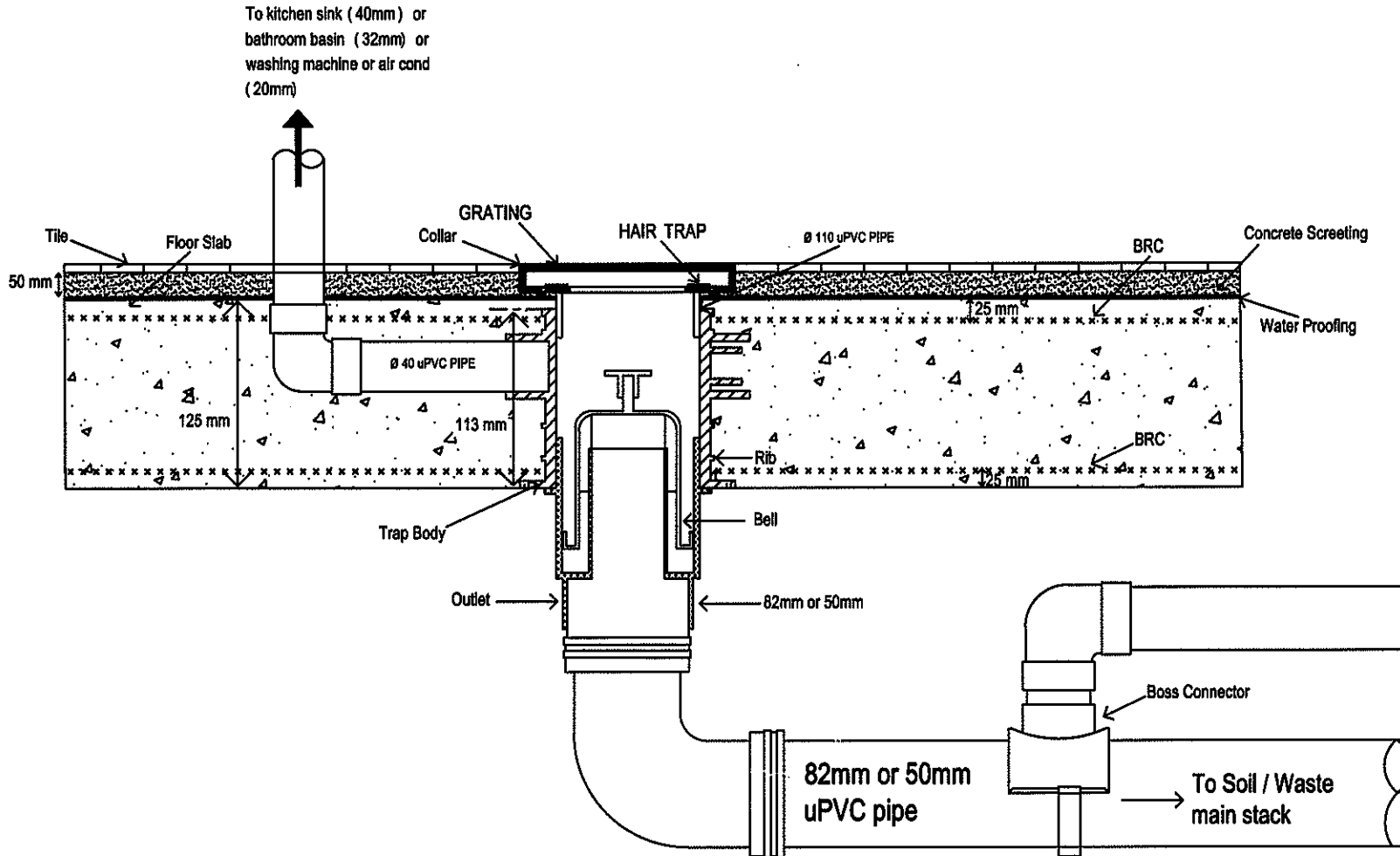

- Cut stand pipe (uPVC) to required height before tiling.
- Place tiles, ensure that collar is flush with tiles.
- Place bell in body of trap, then place hair trap and finish job by placing grating.