



CHEZY'S PATENTED POLYETHYLENE (PE) SOCKET FUSION STOP VALVE

The socket fusion technique is a widely used method for assembling HDPE plastic piping systems. The general operating principles consist of a heating phase and a cooling/welding phase.

Chezy's patented Polyethylene (PE) Socket Fusion Stop Valve complies to SIRIM 9 and is the first PE Socket Fusion Valve to be certified to SIRIM 9 Standards.



Brass Handle Design

Square Knob Design

Contemporary Design

Classic Design

Modern Design



**BUATAN MALAYSIA
MADE IN MALAYSIA**

It is **SPAN** approved for use with portable water and is rated for PN16 use.

100% MALAYSIAN MADE

BENEFITS OF THE CHEZY PE SOCKET FUSION STOP VALVE:

- Chezy's Socket Fusion valve can be used in place of threaded fittings for jointing with HDPE pipes
- Chezy's Socket Fusion valve need not be bevelled for weld preparation

SOCKET FUSION WELDING PARAMETERS

DN	HEATING TIME (sec)	FUSION TIME (sec)	COOLING TIME (sec)
15	7	5	2
20	10	5	2
25	12	6	4

CHEZY POLYETHYLENE SOCKET FUSION STOP VALVE

PIPE INSERT MUST BE USED FOR HDPE PIPES DURING SOCKET FUSION

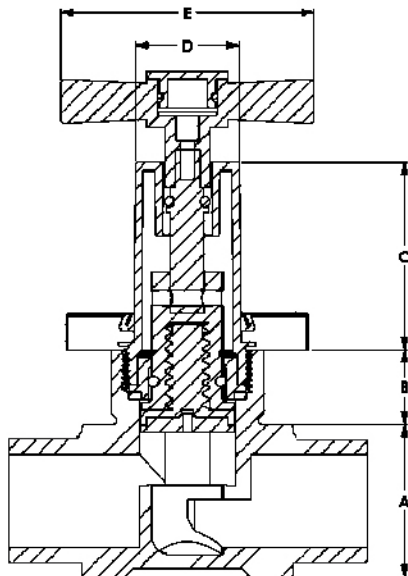
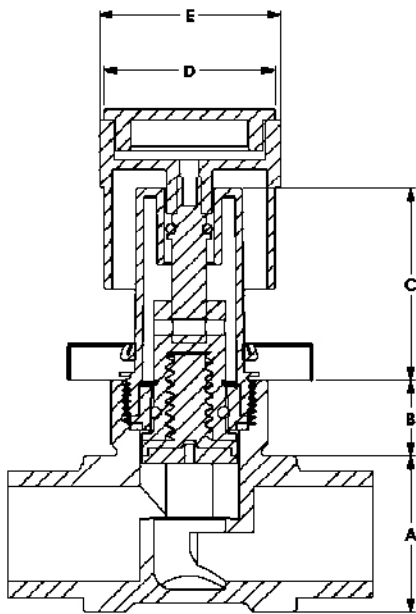

Item	Size (mm)	Dimensions				
		A	B	C	D	E
Metal Sleeve (X, T)	1/2" / 15 mm	30	24	51	28	60
	3/4" / 20 mm	37	20	51	28	60
	1" / 25 mm	45	20	51	28	60
Long Metal Sleeve (XL, TL)	1/2" / 15 mm	30	24	76	28	60
	3/4" / 20 mm	37	20	76	28	60
	1" / 25 mm	45	20	76	28	60
Classic Handle	1/2" / 15 mm	30	24	51	28	67
	3/4" / 20 mm	37	20	51	28	67
	1" / 25 mm	45	20	51	28	67
Square Knob Handle	1/2" / 15 mm	30	24	76	28	48
	3/4" / 20 mm	37	20	76	28	48
	1" / 25 mm	5	20	76	28	48
Plastic Black Sleeve (XB, TB)	1/2" / 15 mm	30	24	41	28	55
	3/4" / 20 mm	37	20	41	28	55
	1" / 25 mm	45	20	41	28	55
Long Plastic Black Sleeve (XBL, TBL)	1/2" / 15 mm	30	24	76	28	55
	3/4" / 20 mm	37	20	76	28	55
	1" / 25 mm	45	20	76	28	55
Plastic Chrome Sleeve (XC, TC)	1/2" / 15 mm	30	24	41	28	55
	3/4" / 20 mm	37	20	41	28	55
	1" / 25 mm	45	20	41	28	55
Long Plastic Chrome Sleeve (XCL, TCL)	1/2" / 15 mm	30	24	76	28	55
	3/4" / 20 mm	37	20	76	28	55
	1" / 25 mm	45	20	76	28	55
Brass Handle Plastic (T)	1/2" / 15 mm	32	21	30	28	51
	3/4" / 20 mm	38	17	30	28	51
	1" / 25 mm	47	18	30	28	51

For more information, please contact our trained professionals and engineers.



CHEZY INDUSTRIES SDN BHD

No. 22, Jalan Uranus AK U5/AK, Taman Subang Impian, Seksyen U5, 40150 Shah Alam, Selangor Darul Ehsan
Tel : 03 - 7859 9499 Fax : 03 - 7832 1655 Email : enquiry@chezy.com.my Website : www.chezy.com.my

All brand and/or product names are trademarks of their respective owners. Specifications and external appearance are subject to change without notice. The actual product may vary from images shown in the brochure. The images in this brochure are not real photographs and may have slight differences in detail might appear. Copyright © 2022 Chezy Industries Sdn Bhd. All rights reserved. This brochure, its contents and/or layout may not be modified and/or adapted, copied in part or in whole and/or incorporated into other works without the prior written permission of Chezy Industries Sdn Bhd.