

STEP 1 (ALL ACCESS FLOOR TRAP)

NAIL PIPE SLEEVE (WITH SOCKET) TO FORM WORK

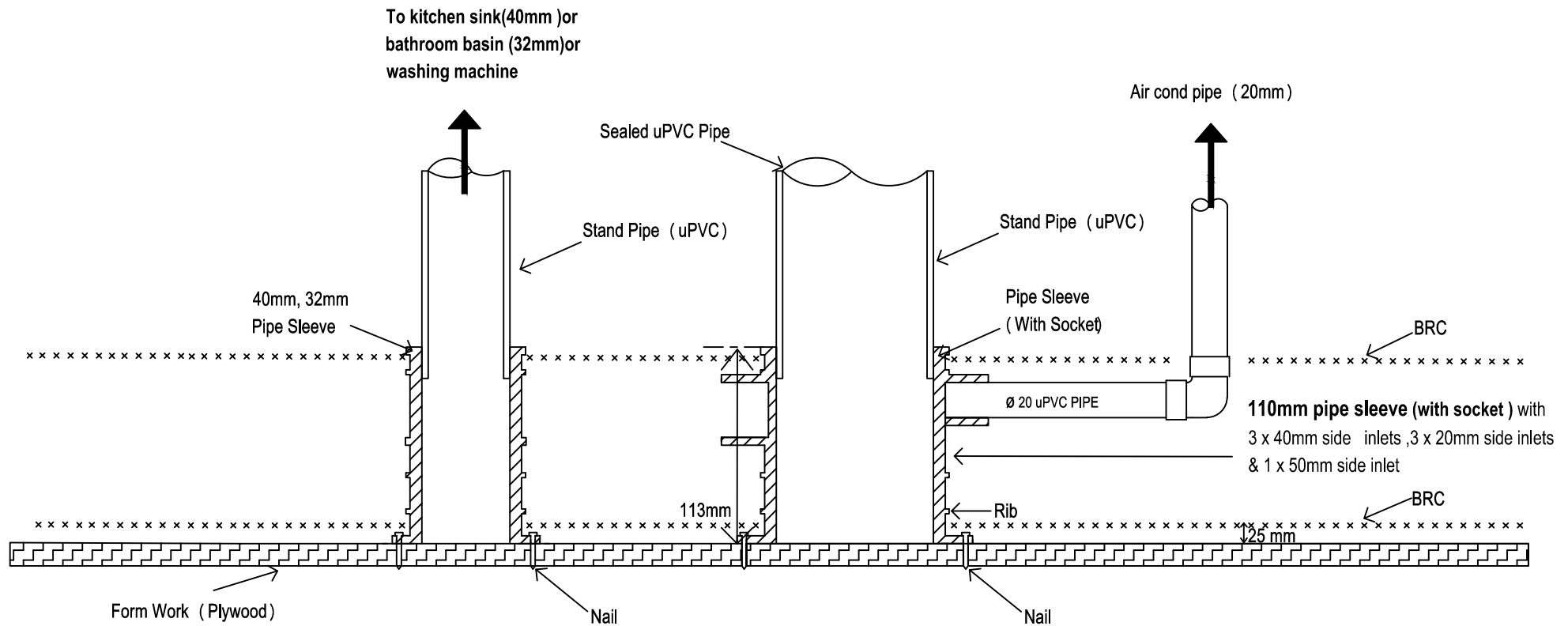

- a) Nail / tie pipe sleeve to form work / BRC before pouring concrete.
- b) Make connections to air cond pipe, basin, sink, etc (if any).

STEP 2 (ALL ACCESS FLOOR TRAP) PIPE SLEEVE (WITH SOCKET) IN SLAB AFTER CONCRETE

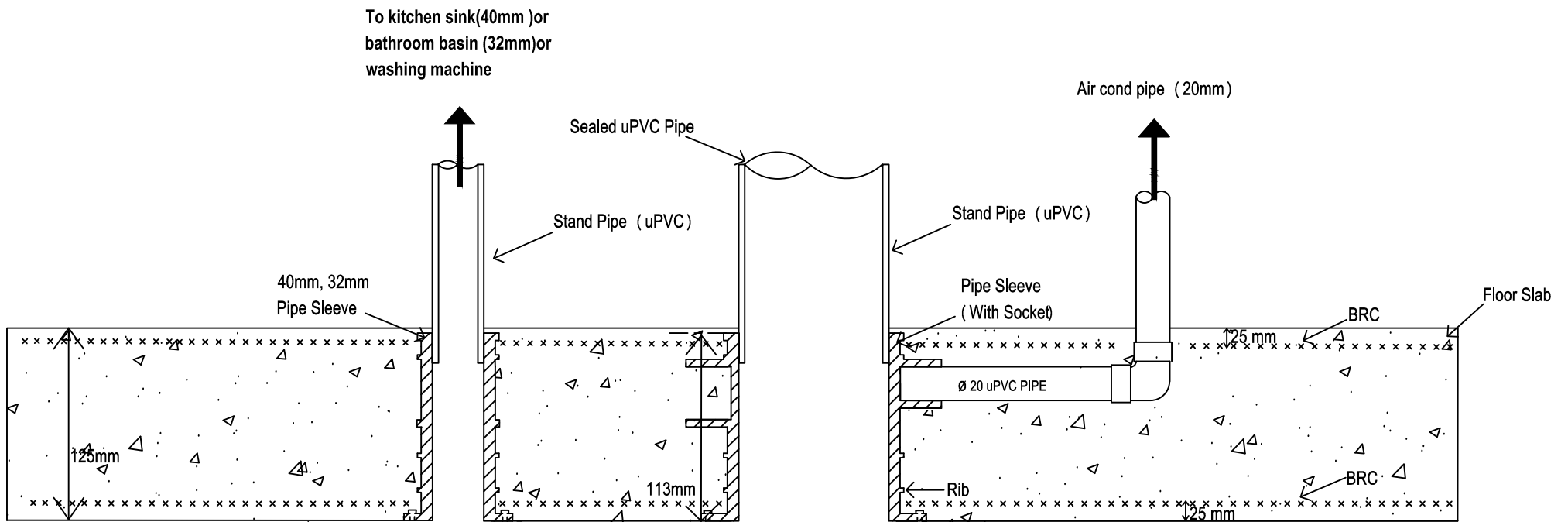

- a) Pour concrete to form floor slab to required height.
- b) Wait for concrete to cure / harden.
- c) Remove form work.

STEP 3 (ALL ACCESS FLOOR TRAP)

PIPE SLEEVE (WITH SOCKET) IN SLAB AFTER CONCRETE WITH REQUIRED LENGTH OF 4" uPVC PIPE (REQUIRED HEIGHT) CONNECTION AT BOTTOM OF PIPE SLEEVE (WITH SOCKET) .

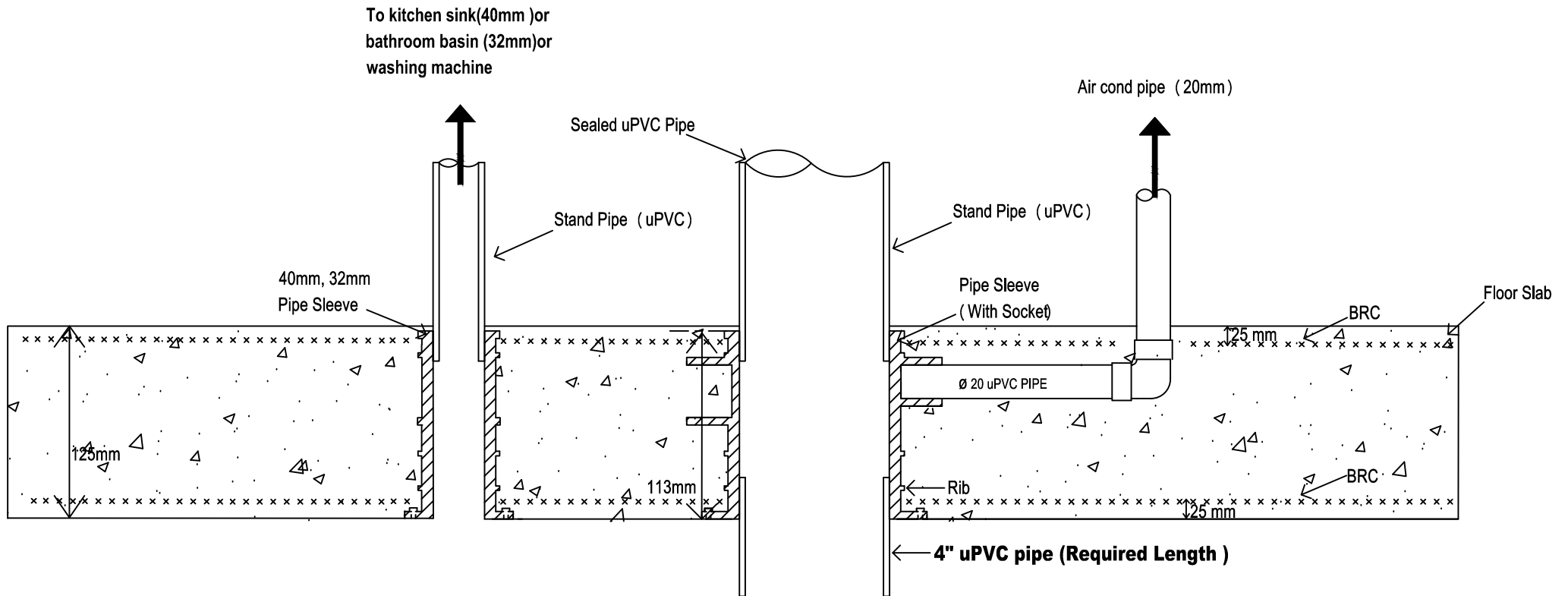

- a) Using solvent cement join short length (required length) of 4" uPVC pipe to bottom of pipe sleeve (with socket) . Ensure that both bonding surfaces are clean before jointing uPVC pipe to the bottom of pipe sleeve (with socket) .

STEP 4 (ALL ACCESS FLOOR TRAP)
PIPE SLEEVE (WITH SOCKET) IN SLAB AFTER CONCRETE WITH SHORT LENGTH
OF 4" uPVC PIPE (REQUIRED HEIGHT) CONNECTION AND FLOOR GULLY BODY

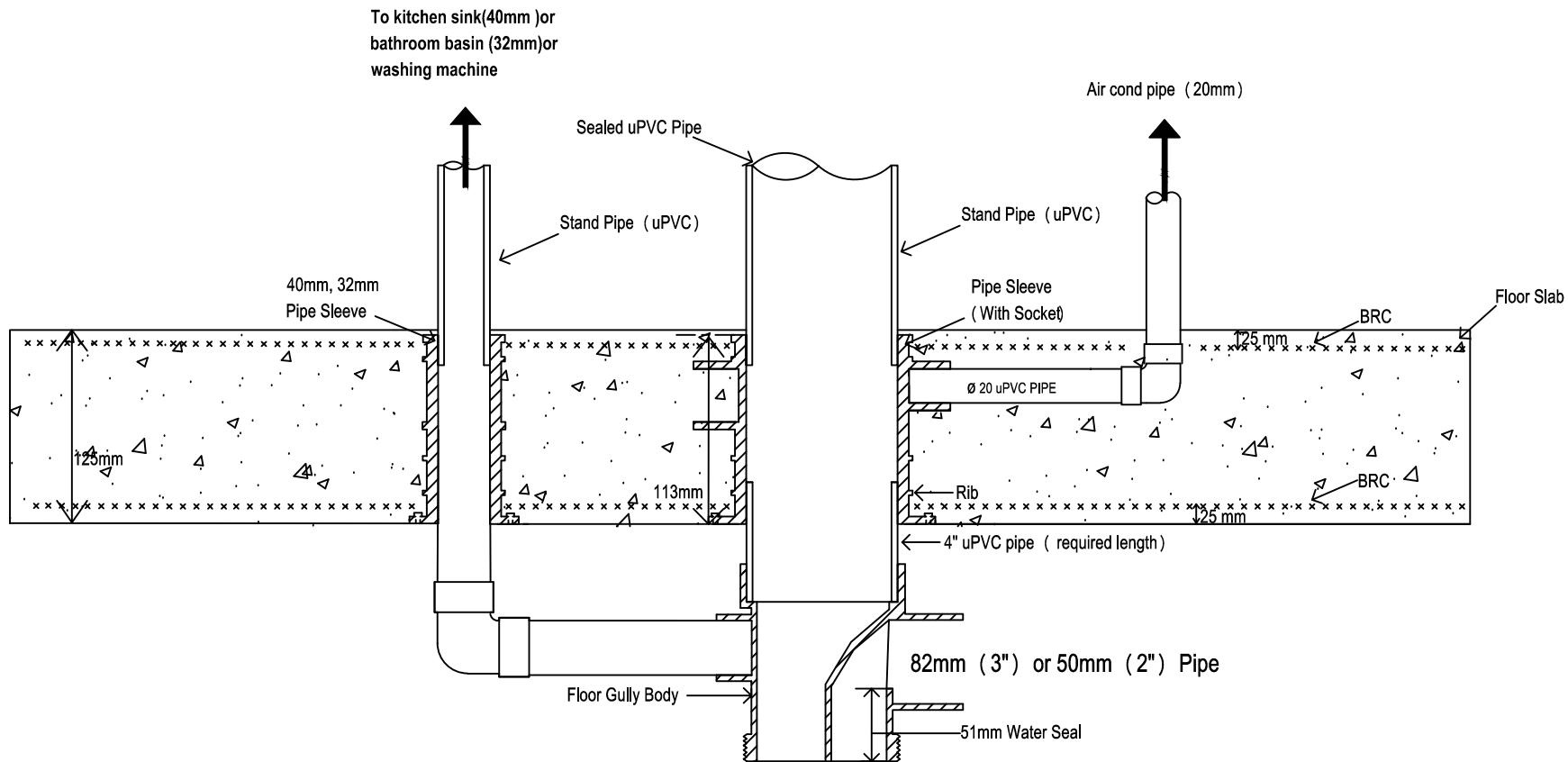

- a) Using solvent cement to join floor gully body to 4" uPVC pipe below slab.
- b) Using solvent cement , connect basin, kitchen sink piping to socket of floor gully body.

STEP 5 (ALL ACCESS FLOOR TRAP) FLOOR GULLY BODY CONNECTION WITH THE MAIN STACK

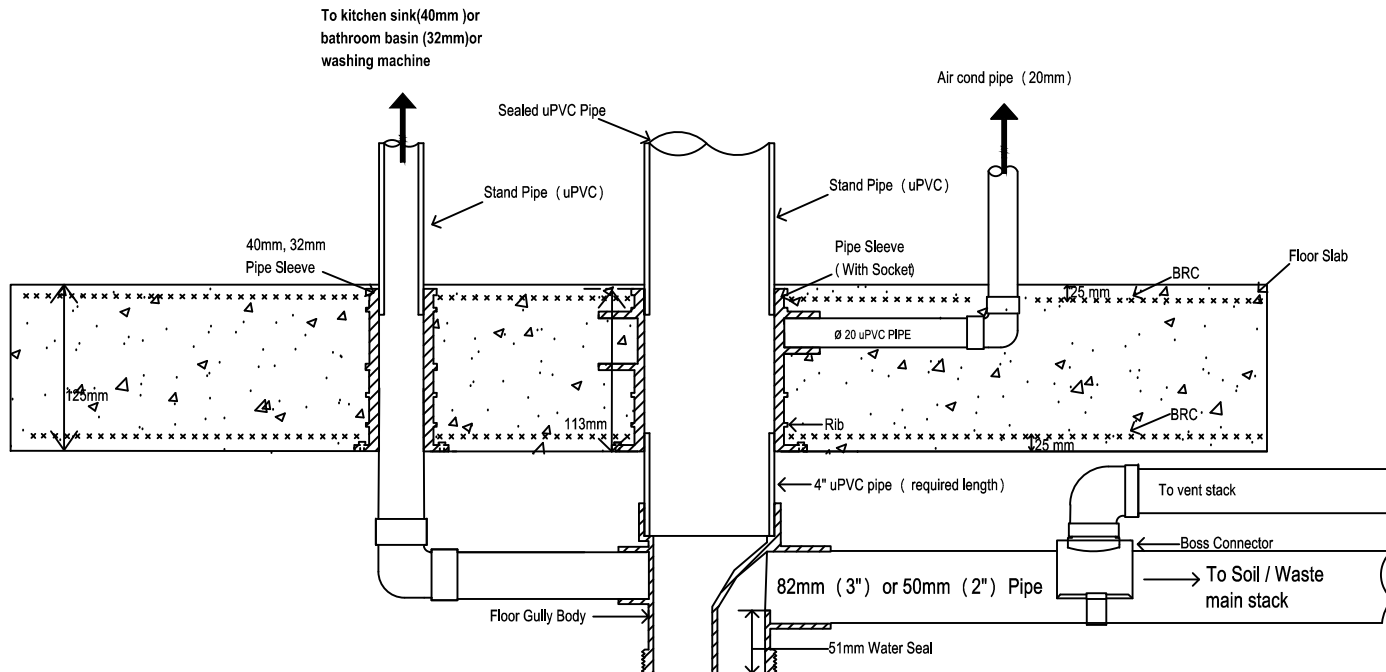

- Using solvent cement, join outlet pipe (2" or 3" uPVC pipe) ensuring a gradient of $1\frac{1}{4}$ degree in the outlet pipe going to the main stack.
- Support the incoming and outgoing uPVC pipes from the floor gully as per the table below :-

Nominal Size (mm)	Maximum spacing of supports (m)	
	Vertical pipes	Graded pipes
20,32,40,50	2	1
82	2.5	1.2

STEP 6 (ALL ACCESS FLOOR TRAP)

WATER PROOFING AND CONCRETE SCREEDING

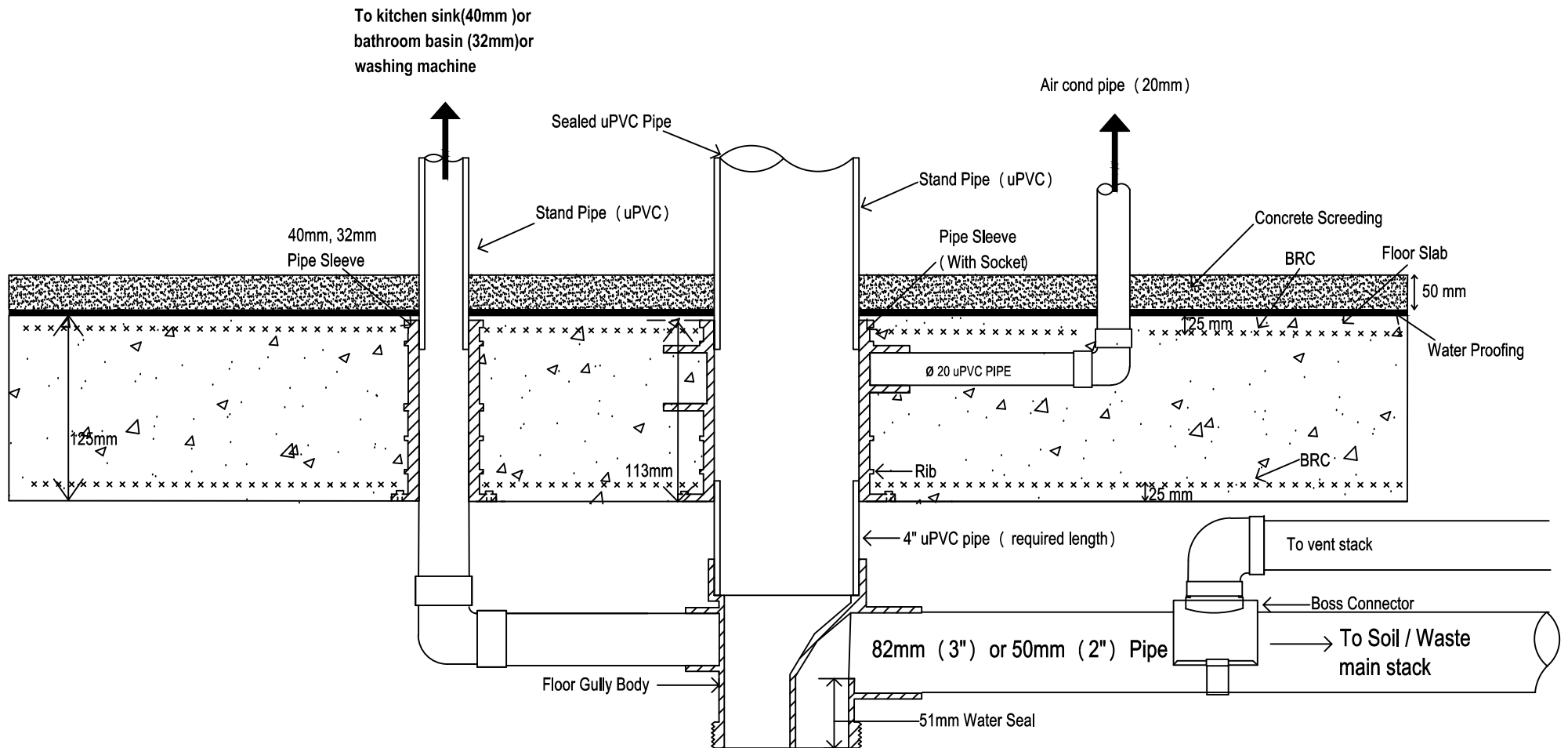

- Apply water proofing (to required height) .
- Screed to required height.

STEP 7 (ALL ACCESS FLOOR TRAP) TILING AND COLLAR INSTALLATION

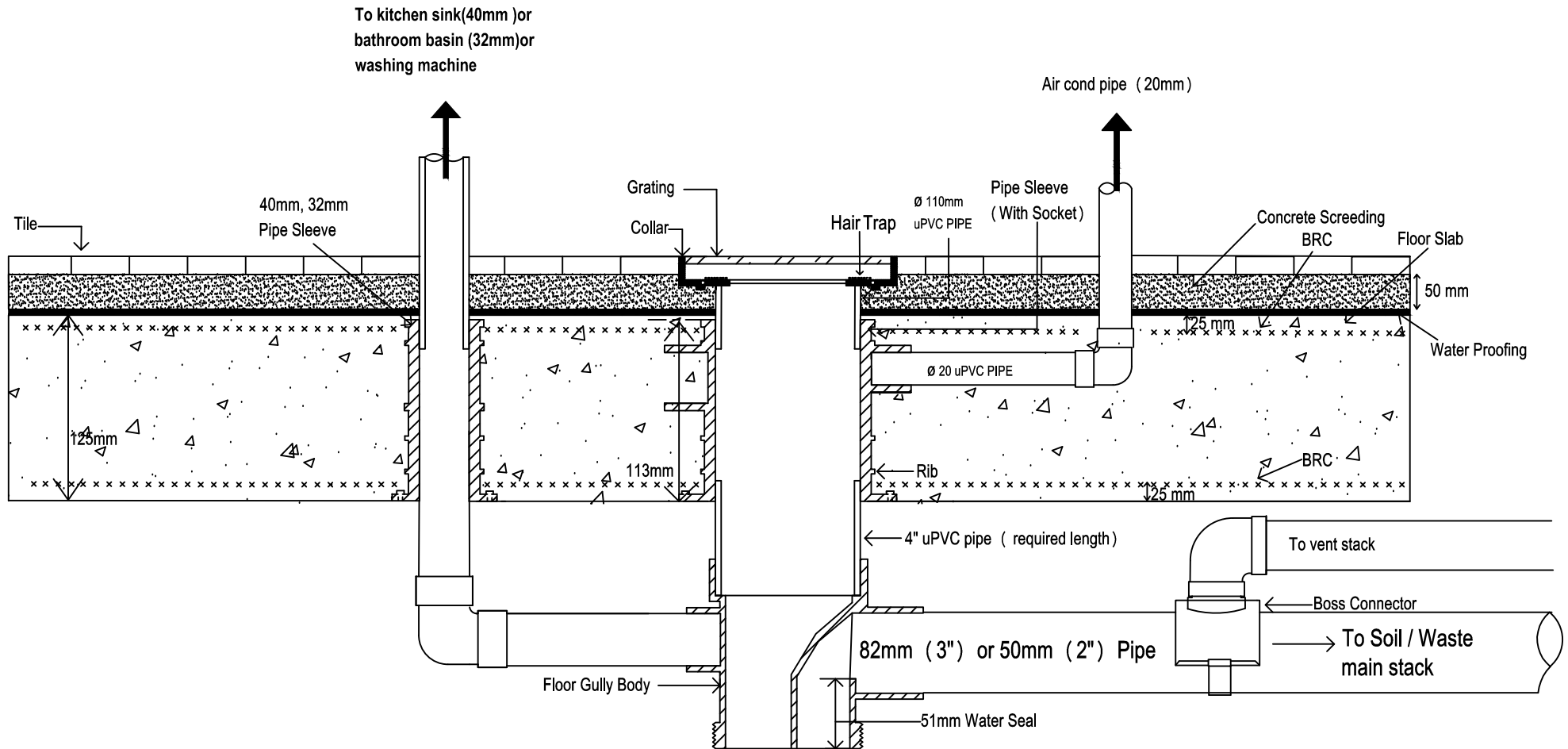

- a) Cut stand pipe (uPVC) to required height before tiling.
- b) Place tiles, ensure that collar is flush with tiles.

STEP 9 (ALL ACCESS FLOOR TRAP)

COMPLETE INSTALLATION OF ALL ACCESS FLOOR TRAP

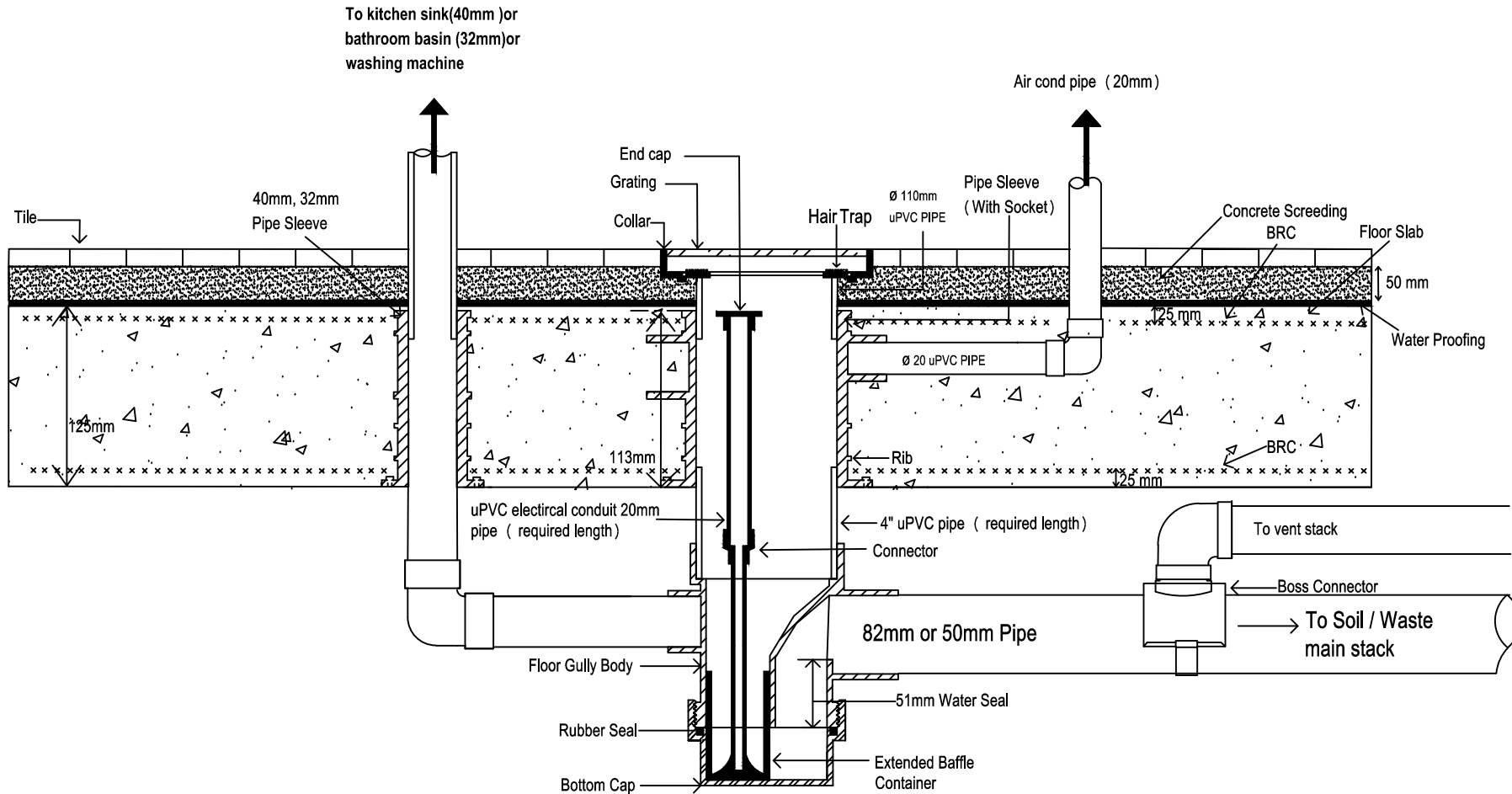

- Place baffle container in floor gully body to 1 inch below the grating.
- All access floor trap installation is completed.